

# Service Manual

**Model : LCDM-2000**  
**(Cash Dispensing Module)**

**Total Page : 38 pages (including cover)**

**Date : 2001. 12**

**Version : V2.1**



***PULOON Technology Inc.***

**= Contents =**

**1. Functional Description**

**1-1. Instruction**

**1-2. Specification**

**1-3. Cash Cassette Structure**

**1-4. Feed Module Structure**

**2. H/W Constitution**

**2-1. Main Board Parts Layout**

**2-2. Main Board Connector Layout**

**3. Error Code & Handling Method**

**3-1. Error Code & the details**

**3-2. Handling method according to Error Code**

**4. Self Diagnostic Mode using PC**

**4-1. Program Loading**

**4-2. Setting Procedure**

**4-3. Program Usage**

# 1. Functional Description

## 1-1. Introduction

This Specification is related to LCDM-2000 which is applied to ATM for Retail Market & other Bill Exchanger.

LCDM-2000 consists of Feed Module, Upper & Lower Cash Cassette, Reject Tray & Main Controller. Features is below

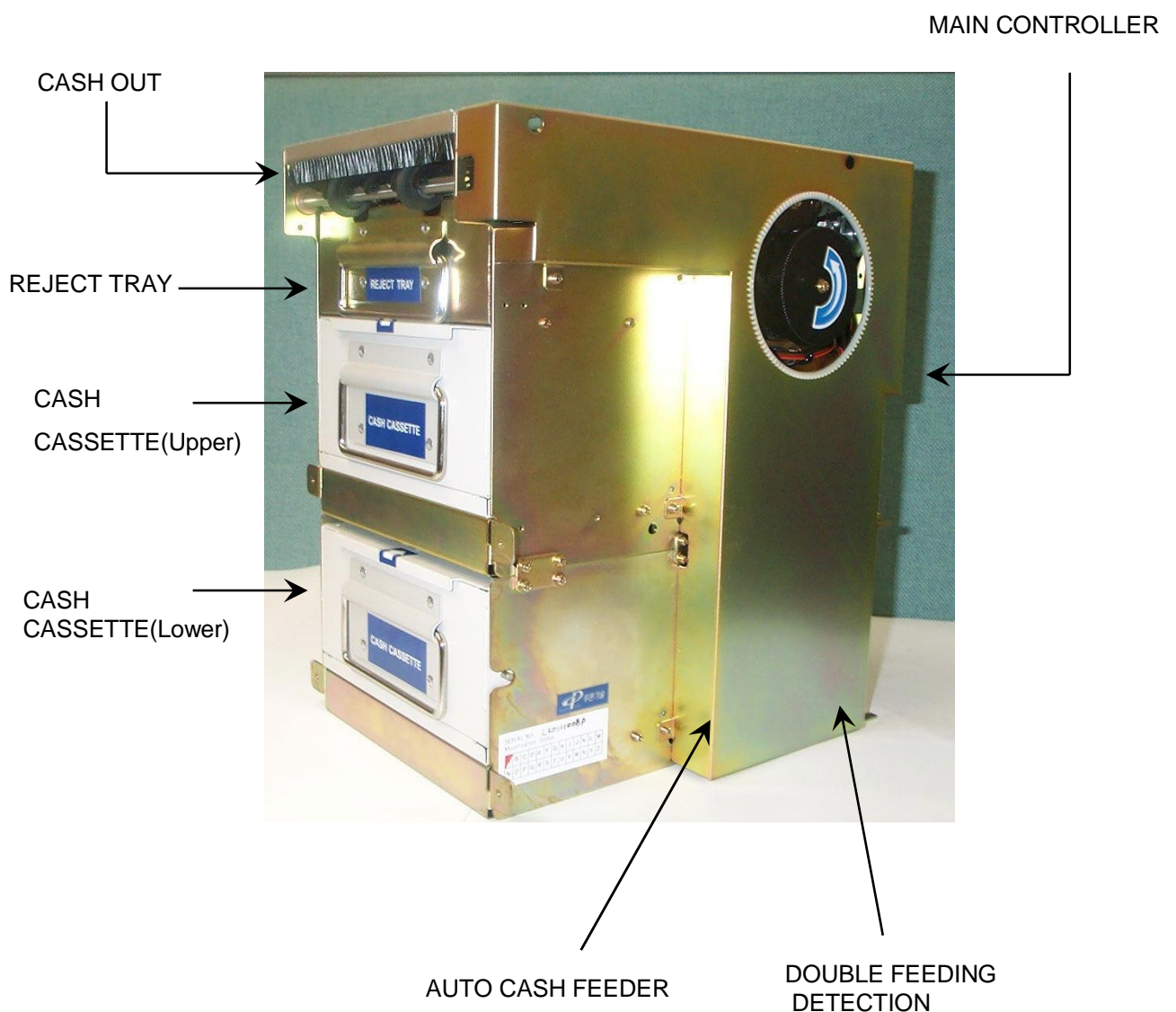

1-2. Specification

NO	Term	Specification
1	Denomination	2 denomination
2	Cassette Capacity	123 mm pile of notes
3	Dispensing Speed	3 note/sec.
4	Usage Notes Size	height : 62mm~78mm , width : 100mm~162mm
5	Double Feeding Detection	Included (Mechanical Method)
6	Reject Tray Capacity	Approximate 30 notes
7	Access Type	Front Type
8	Input Voltage	DC 24V
9	Interface	RS 232C
10	Dimension	310.2(D) x 356(H) x 266.7(W) ( Unit:mm)
11	Near-end Detection	Approximate 30 ~50 notes
12	Bill-End Detection	0 or Approx. 10~30 notes (by setting dip switch )
13	Current	waiting : 160 mA , normal dispensing : 1200 mA
14	Operating Temperature	5° C ~ 40°C

### 1-3. Cash Cassette Structure

Cash cassette do the role of transporting inserted bill one by one to next module and consists of Cassette Door,Cassette Body & Cassette base

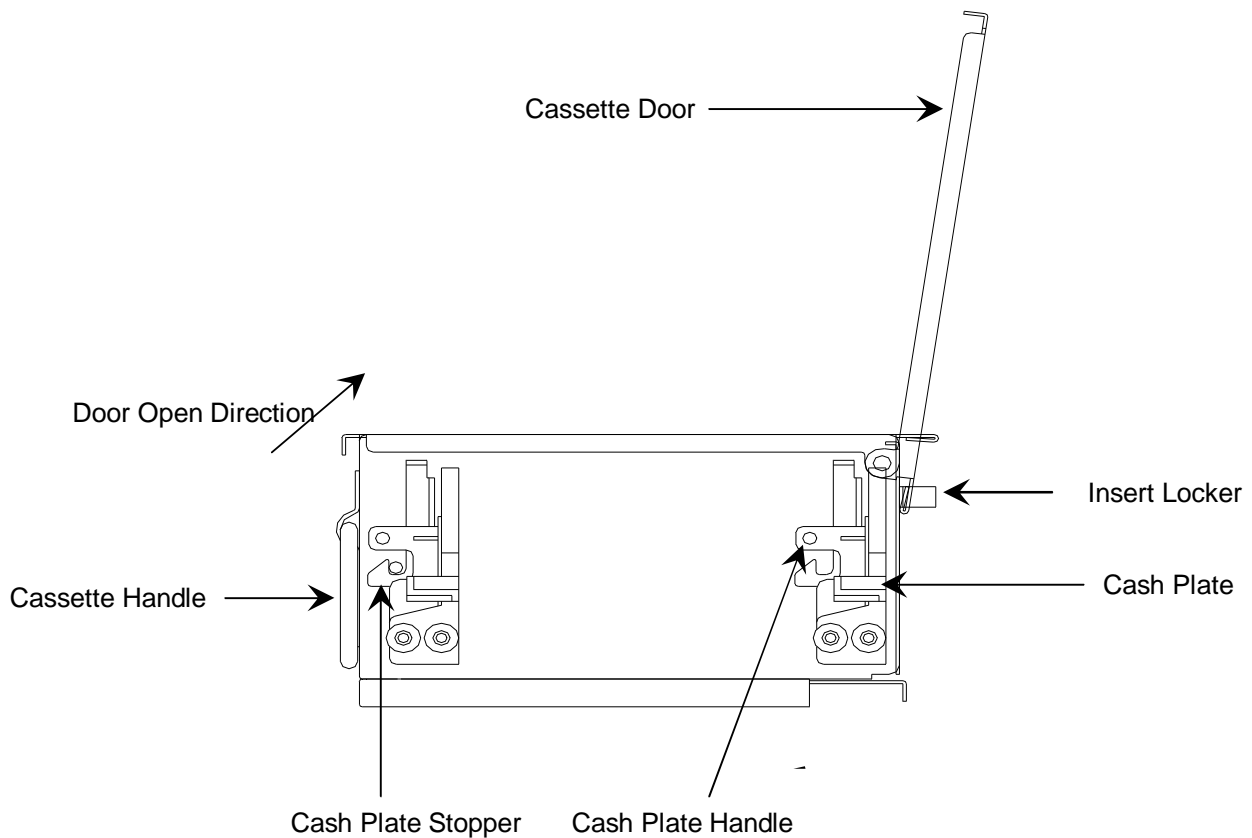

### 1-3-1. Capacity & Currency of Cash cassette

Capacity is approximately 123 mm( I.E about 1,000 bills can be stacked base on new note) & usable currency dimension is as below diagram

Minimum		Maximum	
Height	Width	Height	Width
62mm	100mm	78mm	162mm

### 1-3-2. Cash cassette door

Cash cassette door is magnetically closed & can be opened  
If pushed label direction without special locker

### 1-3-3. Cash Cassette Body

Cash cassette body consists of frame,pushing plate & stopper.  
Pushing plate moves bill to “Pick-up roller” along with side- slot by power of spring.  
Hook & Axle of stopper is in the rear of “pushing plate & frame” respectively.  
Stopper is automatically closed & opened by backing pushing plate and opening door respectively.

### 1-3-4. Cash Cassette Base

When cash cassette is inserted, the part of transporting open automatically  
by the function of Cash cassette base which is located in the part  
of transporting part.

### 1-3-5. Bill-End Detection

The Bill-End detection can be decided by dip switch (the 1<sup>st</sup> switch on the SW1).

If you set the switch “ON”, the unit continues to dispense until approximately 10~30 bills remains, and then Bill-End sign will displayed with stopping the unit.

Else if you set the switch “OFF”, the unit continues to dispense until none of bills remain, and then Bill-End sign will displayed with stopping the unit.

There is hole in the front of “Cash Cassette” and detection process is done by this hole. ( Please refer to the layout of sensor for location)

### 1-4. Feed Module Structure

Feed Module consists of auto cash feeder part , double feeding detection part , diverting mechanism part , cash delivery part and Feature is shown below.

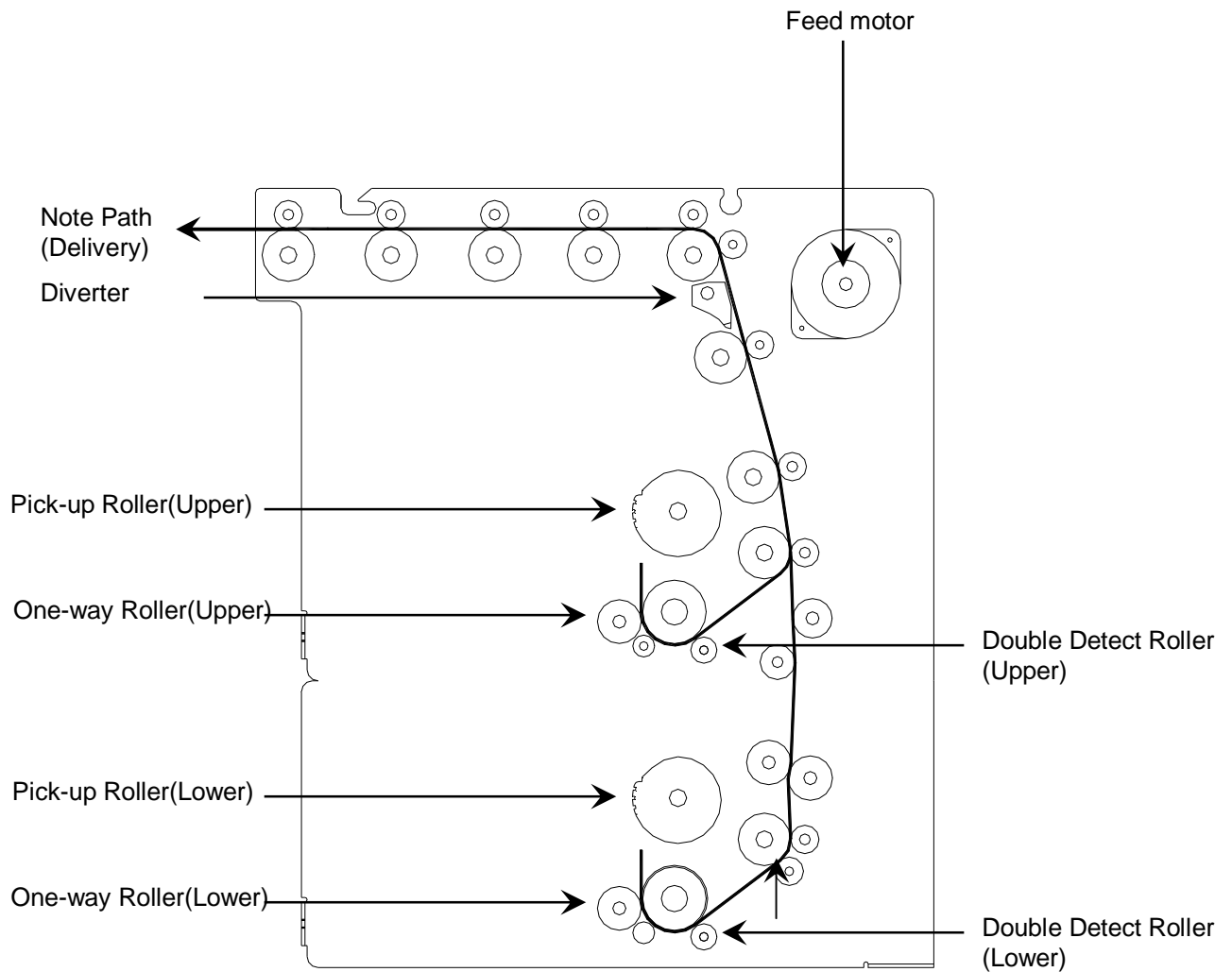



1-4-1. Auto Cash Feeder Part

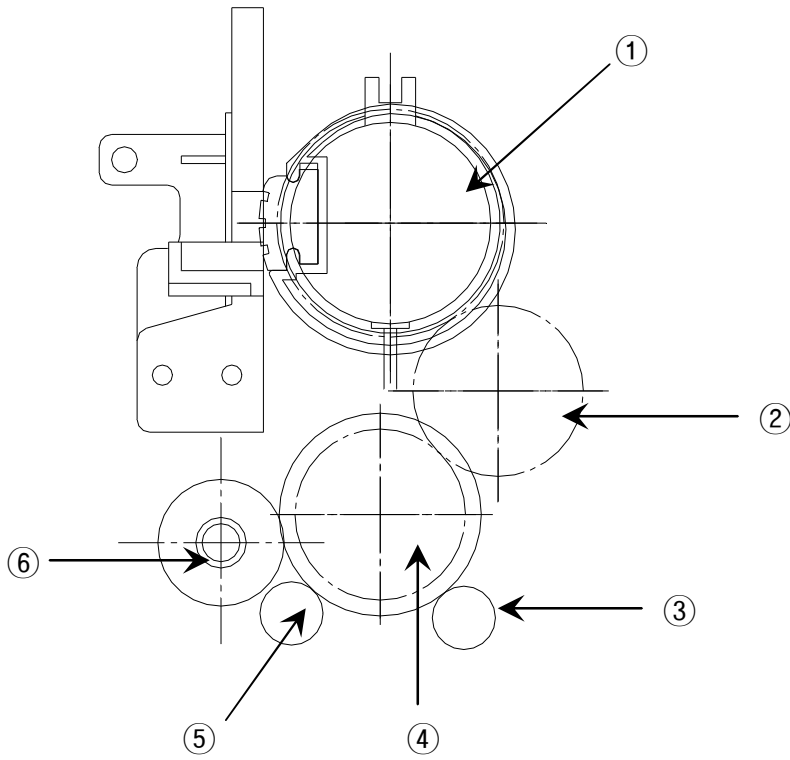

< Auto Cash Feeder >-

**(1) Features**

- Friction roller feeding
- Feeding speed : 3 bills/sec
- Force transportation by clutch on/off

**(2) Description**

<b>NO</b>	<b>Description</b>	<b>Function</b>
①	SHAFT PICK-UP ROLLER ASS'Y	Pick-up & moving bills in the cash cassette
②	SHAFT SPACE CONNECTION ASS'Y	Force transportation of ① & ④ parts
③	ROLLER IDLE	Moving bills by spring force
④	SHAFT FEED ROLLER ASS'Y	Separation & moving bills which was picked up
⑤	BEARING R-1030	Moving bills by spring force
⑥	SHAFT ONEWAY ROLLER ASS'Y	Separation of bills which was pick-up

1-4-2. Double Feeding Detection Part

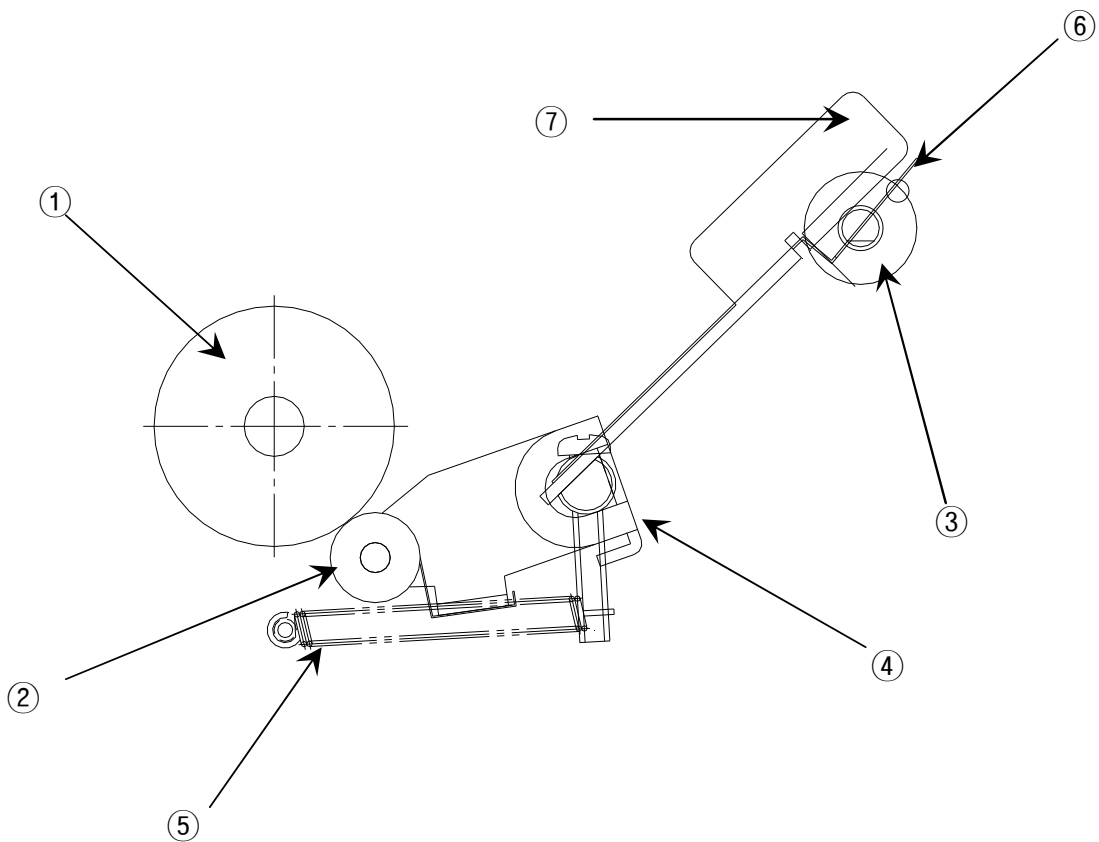
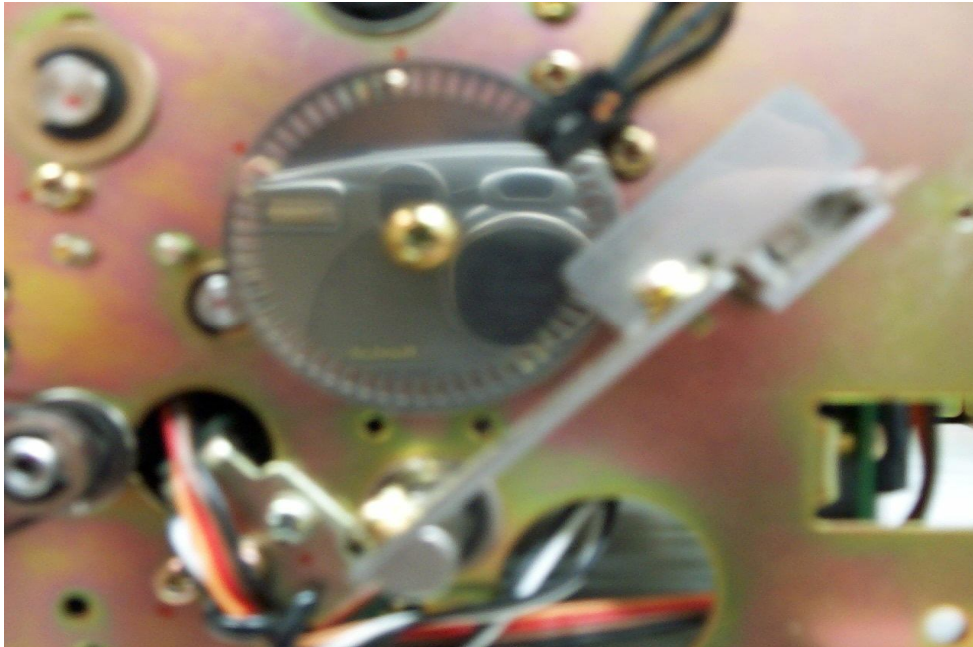

< Constitution of Thickness Recognition >

(1) Features

- Thickness recognition by Mechanical Amplification
- Thickness recognition by RVDT segment for rotation

(2) Description

NO	Description	Function
①	SHAFT FEED ROLLER ASS'Y	DATUM ROLLER of thickness recognition Outer dimension is important
②	BEARING R 1240	DETECT ROLLER, amplification role with rotation as the center of ④ part
③	RVDT segment (LP06M3R)	Recognize rotation displacement Minute & fast speed of recognition
④	ARM D/D HINGE	DETECT ROLLER' rotation LINK and transporting rotation power to ⑦
⑤	SPRING RVDT TENSION	Push power to DETECT ROLLER
⑥	PLATE D/D SENSOR	RVDT' rotation STOPPER and transporting exact displacement using Elasticity
⑦	LEVER D/D HINGE	Transporting ④ rotation power with amplification using RVDT

1-4-3. Diverting Mechanism Part

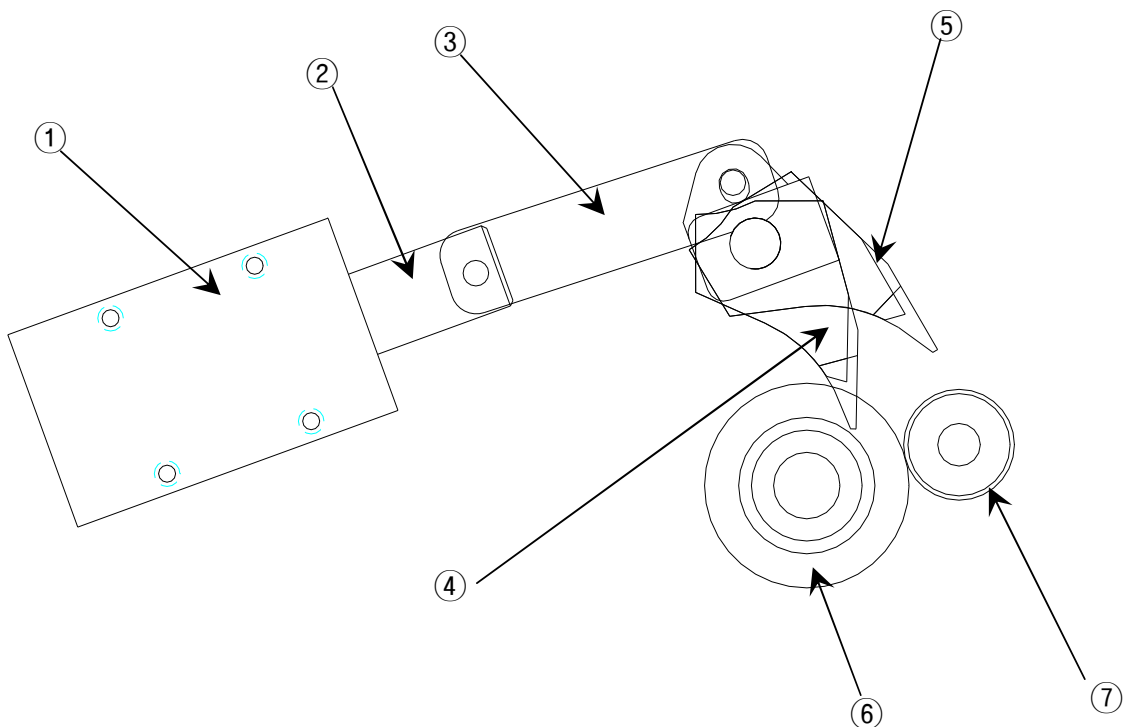
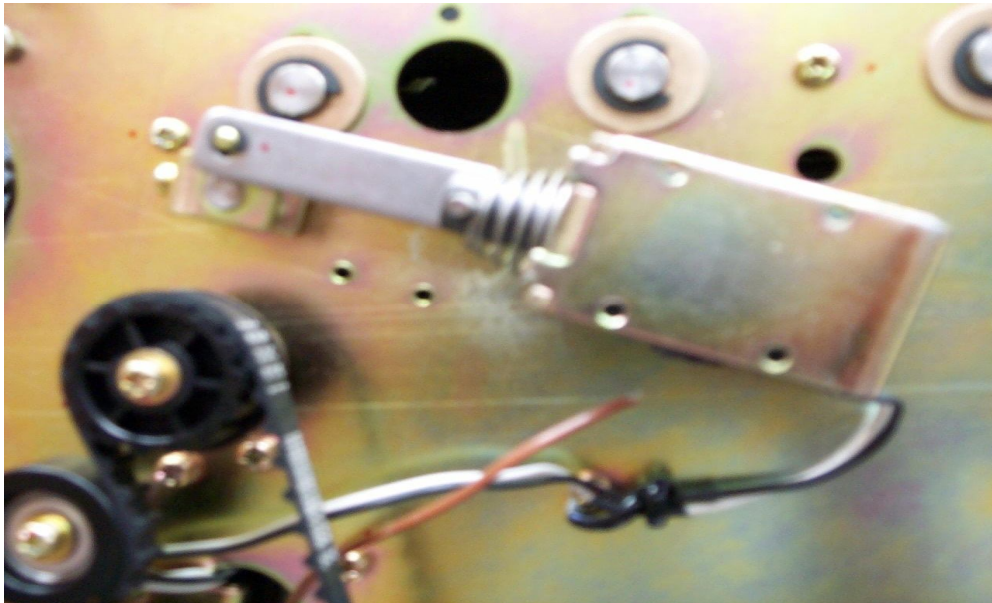

< Constitution of divergence part >

(1) Features

- A sheet resentment by DC Solenoid
- Simplification of Transportation part by Single PATH Method

(2) Description

NO	Description	Function
①	SOLENOID 1040 JUWON	SOLENOID for Divergence
②	SOLENOID PLUNGER	PULL TYPE method PLUNGER
③	LINK SOLENOID STAMP	Transporting SOLENOID' round trip movement
④	SHAFT DIVERTER ASS'Y (normal location)	GUIDE of transportation part & move according to SOLENOID' movement Decision of EJECT & REJECT
⑤	SHAFT DIVERTER ASS'Y (REJECT movement location)	
⑥	SHAFT ASS'Y CASH FEED 3	Bill moving ROLLER
⑦	ROLLER ASS'Y IDLE 13	Bill moving ROLLER

1-4-4. Transportation part

(1) Features

- This part consists of working ROLLER & subordinate ROLLER
- Transportation GUIDE is MOLD GUIDE and embodiment of JAM FREE
- Upper part can be easily separated for Maintenance

(2) Constitution

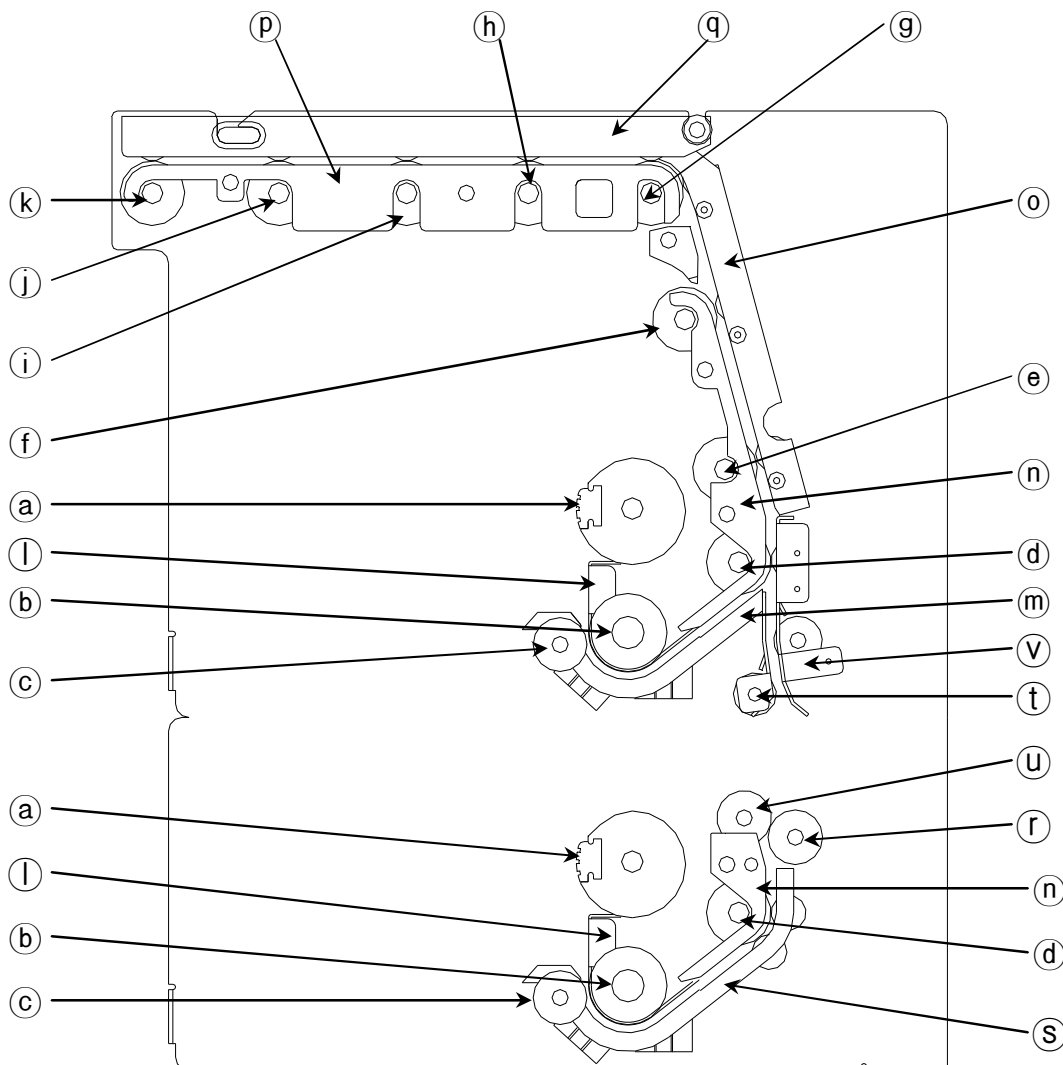

< Constitution of Transportation part >

- Segment Name

NO	Name
a	SHAFT ASS'Y PICK-UP ROLLER
b	SHAFT ASS'Y FEED ROLLER
c	SHAFT ASS'Y ONEWAY ROLLER
d	SHAFT ASS'Y CASH FEED 1
e	SHAFT ASS'Y CASH FEED 2
f	SHAFT ASS'Y CASH FEED 3
g	SHAFT ASS'Y CASH FEED 4
h	SHAFT ASS'Y CASH FEED 5
i	SHAFT ASS'Y CASH FEED 6
j	SHAFT ASS'Y CASH FEED 6
k	SHAFT ASS'Y CASH FEED 6
l	GUIDE CASH FEED 1
m	GUIDE CASH FEED 2 LCDM-2000 ASS'Y
n	GUIDE CASH FEED 3 ASS'Y
o	GUIDE CASH FEED 5 ASS'Y
p	GUIDE CASH FEED 6 ASS'Y
q	GUIDE CASH FEED 7 ASS'Y
r	SHAFT ASS'Y CASH FEED 8
s	GUIDE CASH FEED 2 ASS'Y
t	GUIDE PRESS 2 ASS'Y
u	SHAFT ASS'Y CASH FEED 7
v	GUIDE PRESS 1 ASS'Y



1-4-5. Function & Layout of SENSOR

The number of Sensor is 16. The function & Layout is shown below.

(1) Layout of SENSOR

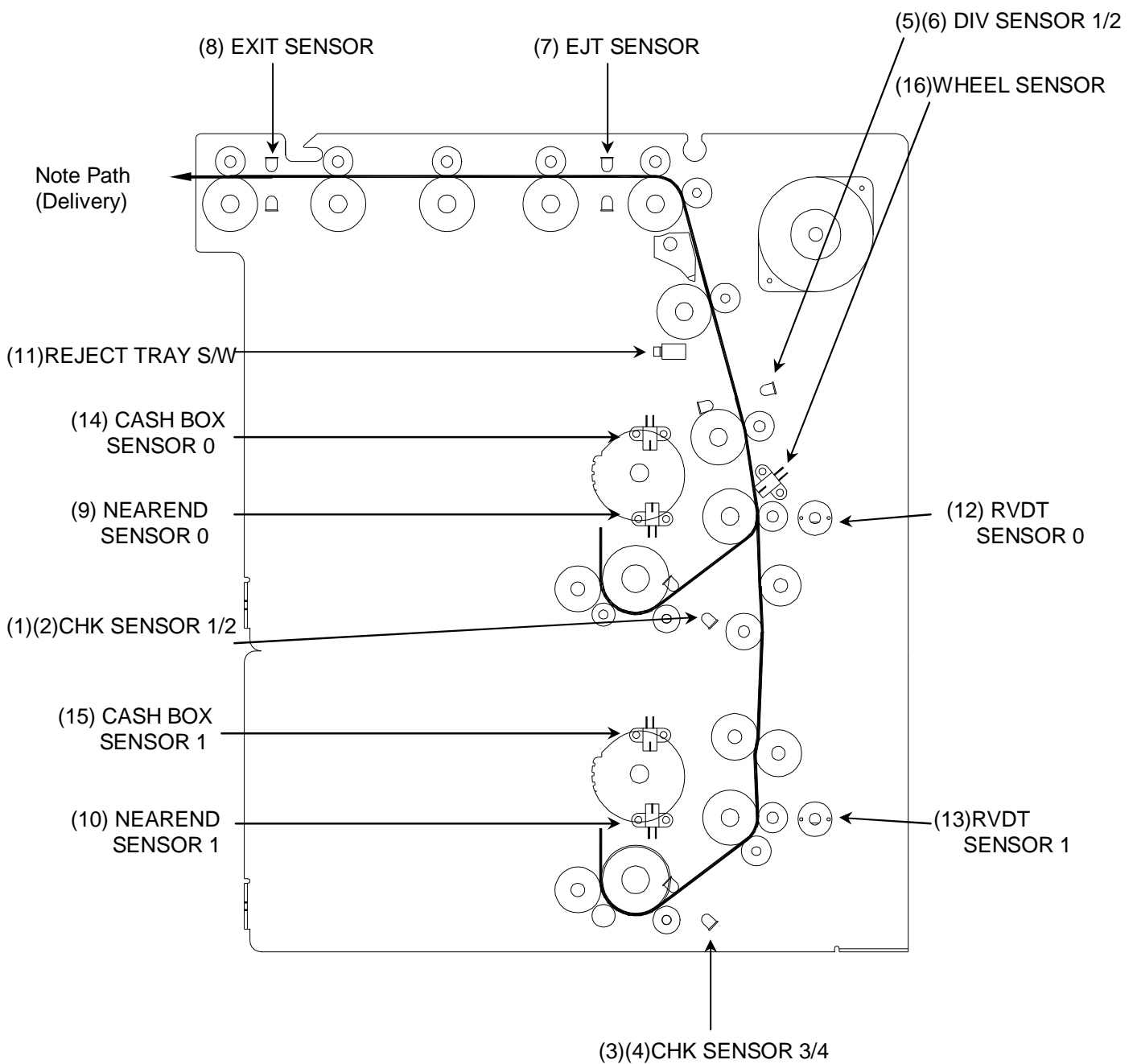

(2) Function of Sensor

NO	SENSOR Name	Function
1	CHK SENSOR 1	Recognition & Length,Width & Slope checking of bill from Cash cassette(Upper Right side)
2	CHK SENSOR 2	Recognition & Length,Width & Slope checking of bill from Cash cassette(Upper Left side)
3	CHK SENSOR 3	Recognition & Length,Width & Slope checking of bill from Cash cassette(Lower Right side)
4	CHK SENSOR 4	Recognition & Length,Width & Slope checking of bill from Cash cassette(Lower Left side)
5	DIV SENSOR 1	Recognition of bill location & role of divergence movement(Right side)
6	DIV SENSOR 2	Recognition of bill location & role of divergence movement(Left side)
7	EJT SENSOR	Recognition of normal bill location
8	EXIT SENSOR	Recognition of the location & the number of normal bill
9	NEAREND SENSOR 0	Recognition the number of remaining in the Upper Cash Cassette
10	NEAREND SENSOR 1	Recognition the number of remaining in the Lower Cash Cassette
11	REJECT TRAY S/W	Checking the status of Reject Tray
12	RVDT SENSOR0	Recognition of thickness of transported bill in the Upper Cash cassette
13	RVDT SENSOR1	Recognition of thickness of transported bill in the Upper Cash cassette
14	CASHBOX SENSOR 0	Checking the Upper Cash Cassette
15	CASHBOX SENSOR 1	Checking the Lower Cash Cassette
16	WHEEL SENSOR	Control of transporting MOTOR speed

1-4-6. Power Transportation part

[1] Features

- Transportation part work by single MOTOR and power for Bill separation part is transferred & controlled by CLUTCH

[2] Constitution

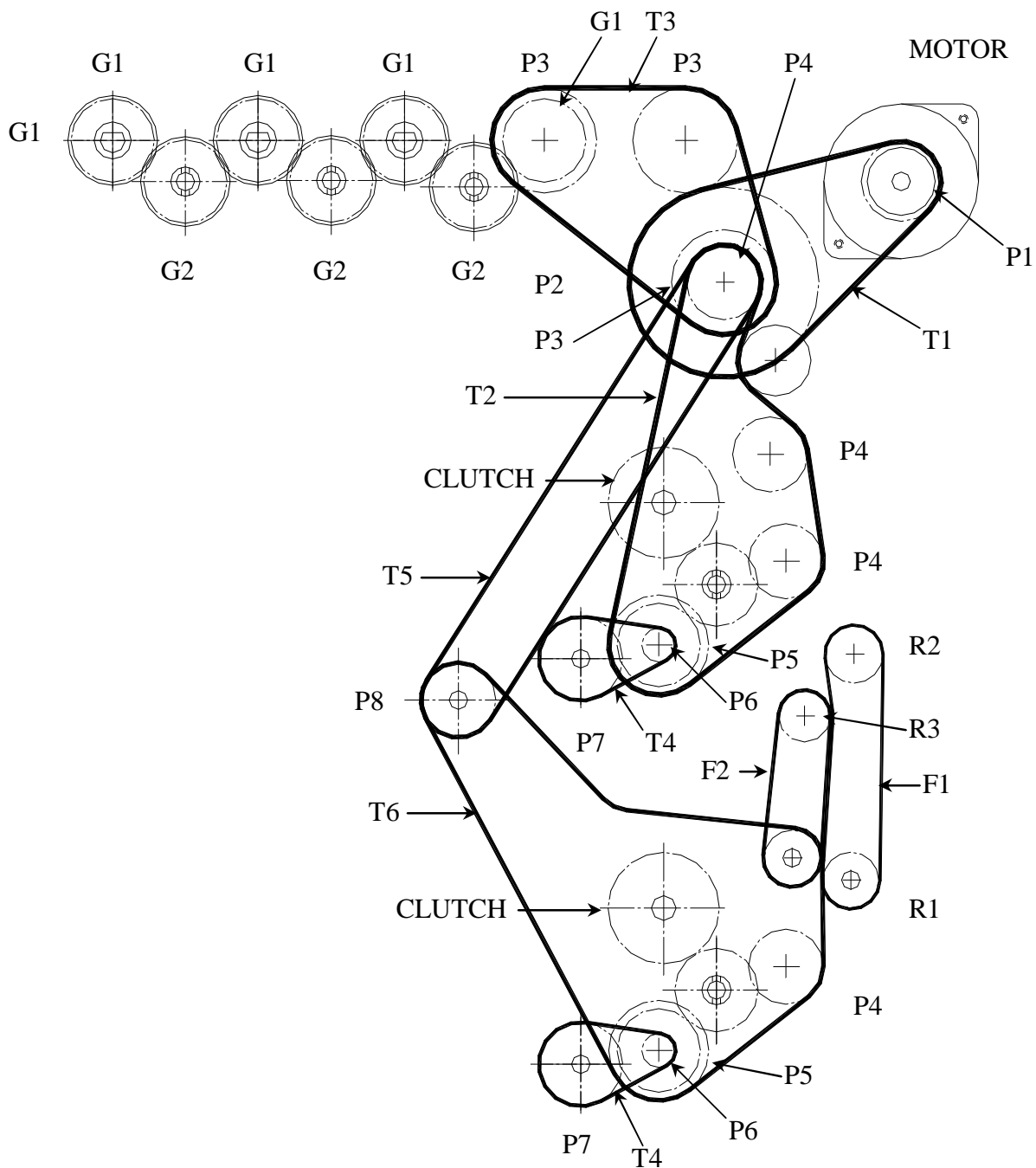

- Segment Name

NO	Name	Function
G1	GEAR FEED (Z:27, M:1)	GEAR for transporting ROLLER
G2	GEAR DFDM DRIVE (Z:27, M:1)	GEAR for transporting POWER
P1	PULLEY MOTOR(XL16, $\phi$ 6)	PULLEY MOTOR
P2	PULLEY CASH FEED 1	PULLEY for reduction of speed
P3	PULLEY CASH FEED 2	PULLEY for transporting ROLLER
P4	PULLEY FEED(XL15, $\phi$ 8)	PULLEY for transporting ROLLER
P5	PULLEY FEED(XL20, $\phi$ 8)	PULLEY for FEED ROLLER working
P6	PULLEY DRV MXL17	For reduction speed of ONEWAY ROLLER
P7	PULLEY REVERSE (MXL42, $\phi$ 8)	For reduction speed of ONEWAY ROLLER
T1	BELT TIMING 108XL(W=6.4)	For MOTOR running & Speed reduction
T2	BELT TIMING 140XL(W=6.4)	For transporting torque to PULLEY ( driving belt )
T3	BELT TIMING 108XL(W=6.4)	For transporting torque to PULLEY ( driving belt )
T4	BELT TIMING 56MXL(W=3.2)	For ONEWAY ROLLER running & Speed Reduction
T5	BELT TIMMING	IDLE PULLY driving belt
T6	<del>56XL(W=6.4)</del> BELT TIMING 166XL(W=6.4)	For transporting torque to PULLEY ( driving belt )
F1	BELT FEEDING PS197 (W=10)	For transporting torque to ROLLER ( driving belt )
F2	BELT FEEDING PS140 (W=10)	For transporting torque to ROLLER ( driving belt )
R1	ROLLER FEED CROWN ( $\phi$ 18)	Driving ROLLER
R2	ROLLER IDLE CROWN ( $\phi$ 18)	Transporting ROLLER
R3	ROLLER IDLE CROWN ( $\phi$ 16)	Transporting ROLLER

**(3) MOTOR**

- MAKER : Fuji Micro
- TYPE : Brushless DC Motor

TYPE	Voltage	No Load		Load			Rot
		Current	Speed	Torque	Current	Speed	
FB-806	DC 24V	180mA± 100mA	4800rpm ±250rpm	1kgf- cm	2400mA± 200mA	3500rpm ±200rpm	CW/ CCW

## 2. H/W Constitution

### 2-1. Layout of MAIN BOARD

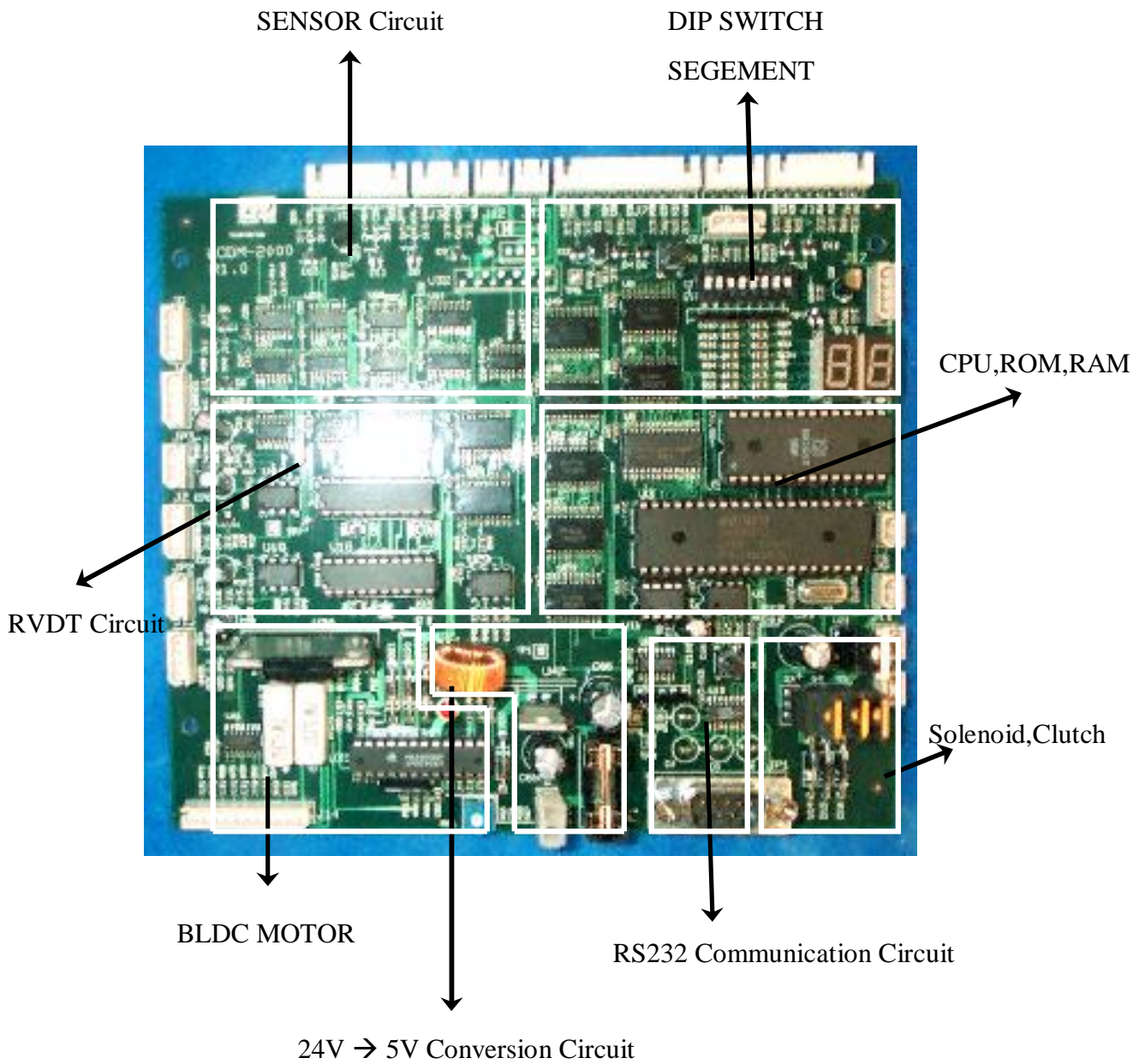

2-2. Connector Layout of MAIN BOARD

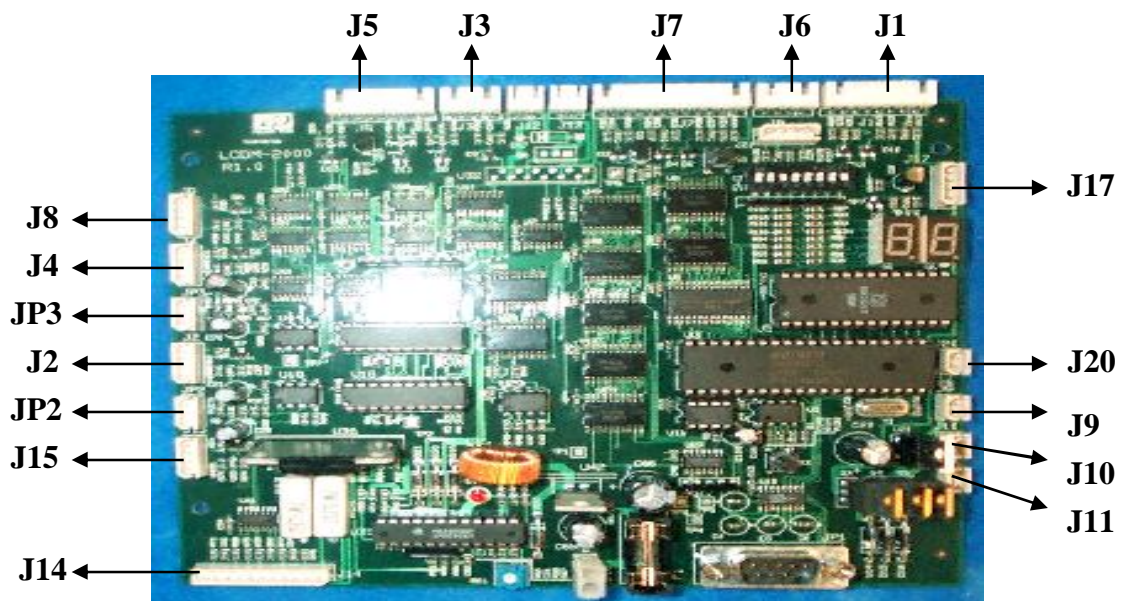

J5	Check1,Divert1 sensor for accepting & emitting light
J3	Eject,Exit emitting sensor
J7	Upper & Lower Cash Box sensor
J6	Eject,Exit accepting sensor
J1	Check2,Divert2 sensor for accepting & emitting light
J8	Check 3 sensor for accepting & emitting light
J17	Check 4 sensor for accepting & emitting light
J4	Lower Near End sensor ( Near End 1 )
JP3	Lower RVDT ( RVDT 1 )
J2	Upper Near End sensor ( Near End 0 )
JP2	Upper RVDT ( RVDT 0 )
J15	Wheel sensor
J14	BLDC Motor
J20	Reject Tray limit switch
J9	Lower Clutch ( Clutch 1 )
J10	Divert Solenoid
J11	Upper Clutch ( Clutch 0 )
J16	POWER
JP1	RS232 Communication

### 3. Error Code & Handling method

#### 3-1. Error code & The details

NO	Code	Indication	The details
1	30	GOOD	
2	31	NORMAL_STOP	Normal Stop
3	32	PICKUP_ERR	PICK-UP Error
4	33	JAM_IN_CRI_UPPER	Jam in the CHK SENSOR 1 / 2 part
5	34	OVERFLOW	Over release of bill
6	35	EXIT_JAM	Jam in the EXIT SENSOR part
7	36	DIVERT_JAM	Jam in the DIV SENSOR part
8	37	RES_TIMEPOT	Incompletion of release in 60 seconds
9	3B	BILL_REQ_ERR	Request bill quantity is over 20
10	3D	BILL_COUNT	There is difference in bill data between EJT SENSOR & EXIT SENSOR
11	3E	SENSOR_ERR	Error in SENSOR
12	3F	SENSOR_REJECT	Open status of REJECT TRAY
13	40	EXIT_JAM1	Dispensed bill fail to arrive at the EXIT SENSOR within 15 seconds
14	41	MOTOR_UNRUN	STOP or low speed of MOTOR
15	42	DIVERT_JAM_RUN	Jam in the DIV SENSOR part
16	43	EJECT_JAM_RUN	TIMEOUT between DIV SENSOR and EJT SENSOR
17	4C	JAM_IN_CRI_LOWR	Jam in the CHK SENSOR 3/4 part
18	45	UPPER_CASH_BOX	No Upper Cash Cassette
19	45	UPPER_CASH_BOX	No Lower Cash Cassette



3-2. Error Code & Management method

CODE	32
Detail	Not being Pick-UP from CASH CASSETTE
Check Point	<ul style="list-style-type: none"> <li>- Is CASH CASSETTE located properly?</li> <li>- Is Bill inserting proper in the CASH CASSETTE ?</li> <li>- Is Push plate work smoothly in CASH CASSETTE?</li> <li>- Is all of bill out from CASH CASSETTE?</li> </ul>
Management	<ul style="list-style-type: none"> <li>- Re install of CASH CASSETTE after checking above</li> <li>- Check NEAREND SENSOR in case of lack of bill</li> </ul>

< Normal Insertion of Bills >



< Wrong Insertion of Bills >



CODE	33 , 4C
Detail	Jam in the CHK SENSOR 1 / 2 or 3 / 4 part
Check Point	<ul style="list-style-type: none"> <li>- Is CHK SENSOR 1&amp; 2 &amp; 3 &amp; 4normal?</li> <li>- Is the assembling condition of GUIDE CASH FEED 1&amp; GUIDE CASH FEED 3 ASS'Y normal ?</li> <li>- Is idle roller rotation in the GUIDE CASH FEED 2 ASS'Y normal?</li> <li>- Is fixing screw in GUIDE CASH FEED 1 / 2 / 3 ASS'Y normal?</li> </ul>
Management	<ul style="list-style-type: none"> <li>- Try again after checking above situation.</li> <li>- In case of Jam, Turn a handle shown below</li> </ul>

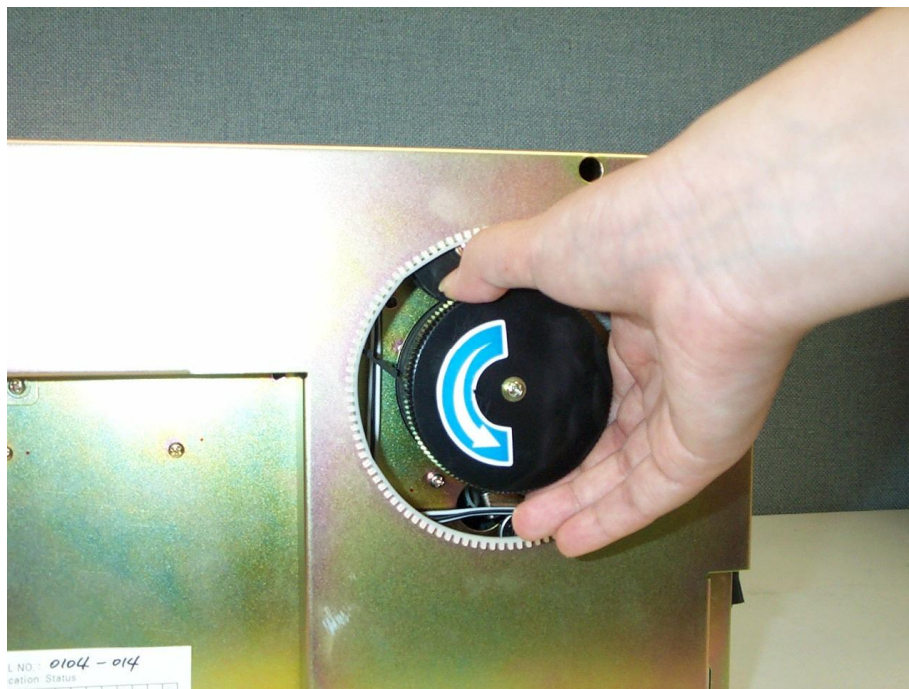

CODE	35, 3D, 43
Details	<ul style="list-style-type: none"> <li>-Jam in EXIT SENSOR part</li> <li>-There is difference in bill data between EJT SENSOR &amp; EXIT SENSOR</li> <li>- TIMEOUT between DIV SENSOR and EJT SENSOR</li> </ul>
Check Point	<ul style="list-style-type: none"> <li>- Are EXIT SENSOR &amp; EJT SENSOR normal?</li> <li>- Is LOCKING device in GUIDE CASH FEED 7 ASS'Y locked normally?</li> <li>- Is idle roller rotation status in GUIDE CASH FEED 7 ASS'Y normal?</li> </ul>
Management	<ul style="list-style-type: none"> <li>- Try again after checking above situation.</li> <li>- Replace ASS'Y in case of roller rotation problem in GUIDE CASH FEED 7 ASS'Y.</li> </ul>

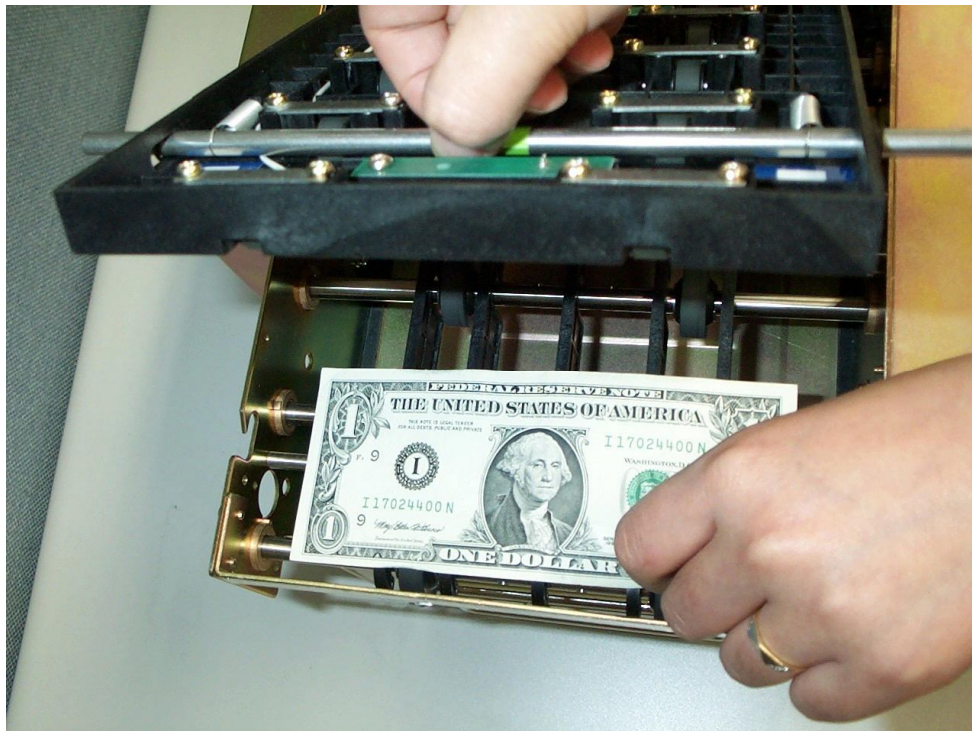

CODE	36, 42
Detail	Jam in DIV SENSOR part
Check Point	<ul style="list-style-type: none"> <li>- Is DIV SENSOR 1 / 2 normal?</li> <li>- Is GAP of SHAFT DIVERter ASS'Y와 SHAFT ASS'Y CASH FEED proper?</li> <li>- Is idle roller rotation in GUIDE CASH FEED 5 ASS'Y normal?</li> </ul>
Management	<ul style="list-style-type: none"> <li>- Try again after checking above situation.</li> <li>- In case of interference between SHAFT DIVERter ASS'Y &amp; SHAFT ASS'Y CASH FEED 3, Adjust location of SOLENOID PIN( Please refer to below picture)</li> <li>- Replace ASS'Y in case of idle roller rotation problem in GUIDE CASH FEED 7 ASS'Y.</li> </ul>

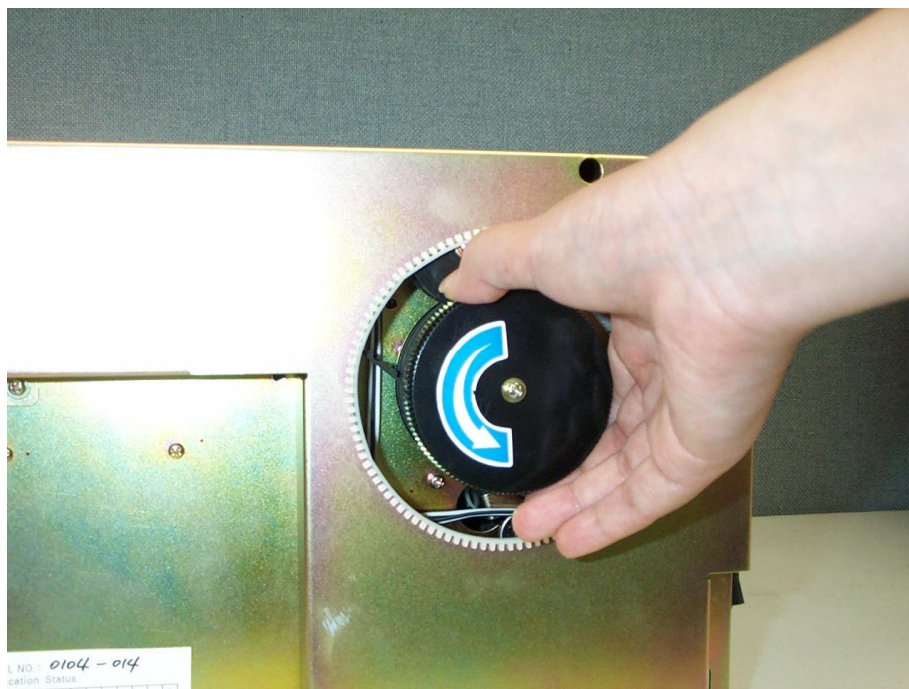

CODE	3E
Detail	Damage to SENSOR
Check Point	- Checking each sensor(Please refer to Self Diagnostic Method )
Management	- Replace damaged SENSOR

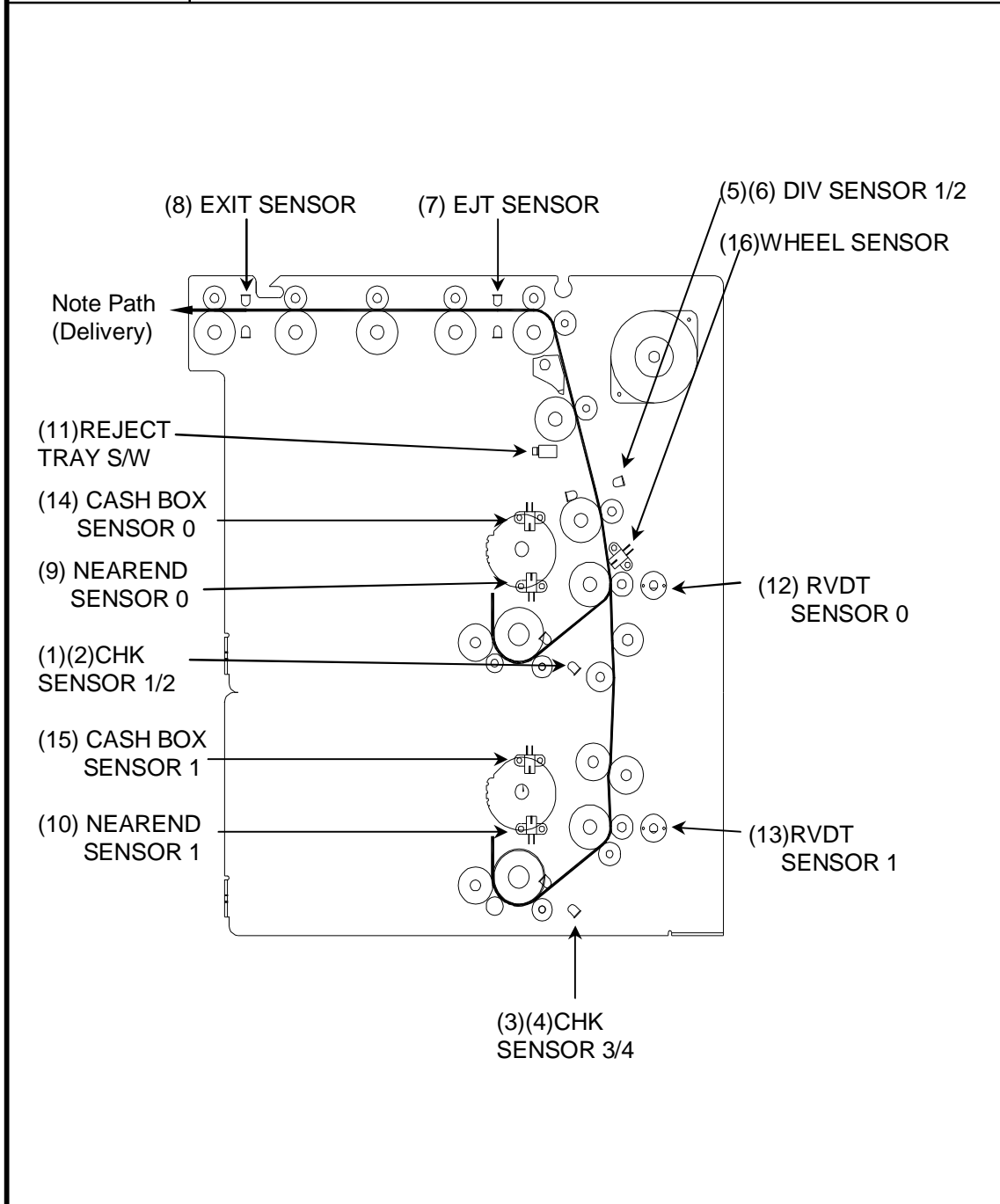

CODE	3F
Detail	REJECT TRAY is not closed
Check Point	-Is the location of REJECT TRAY normal? - Is the location of CONNECTOR normal?
Management	- Insert REJECT TRAY to main body. - Connect J20 CONNECTOR in the MAIN PCB.

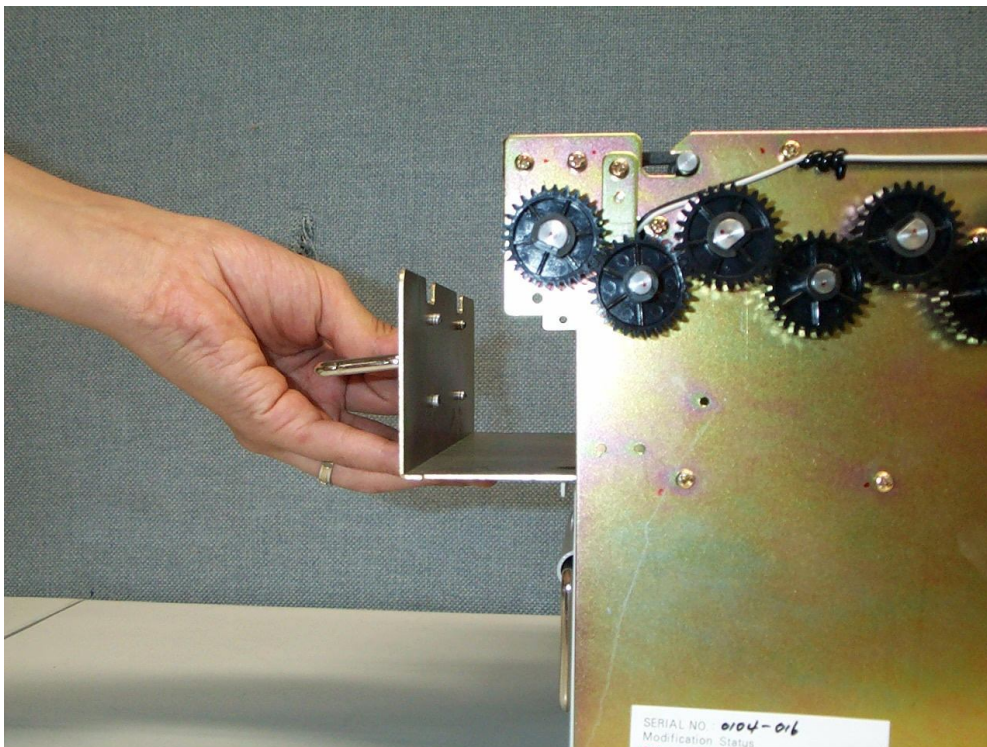

CODE	41
Detail	Stop or low speed of MOTOR
Check Point	- Is any obstacle in Power Transportation part? - Is the location of CONNECTOR correct?
Management	-Try again after checking above situation. - Check J15 CONNECTOR.

4. Self Diagnostic MODE using PC

I. Page 1

- 1) Choose SETUP page !
- 2) Maintain default value like below.  
(If you need to choose another port, check the other port number)
- 3) Press “OK” button

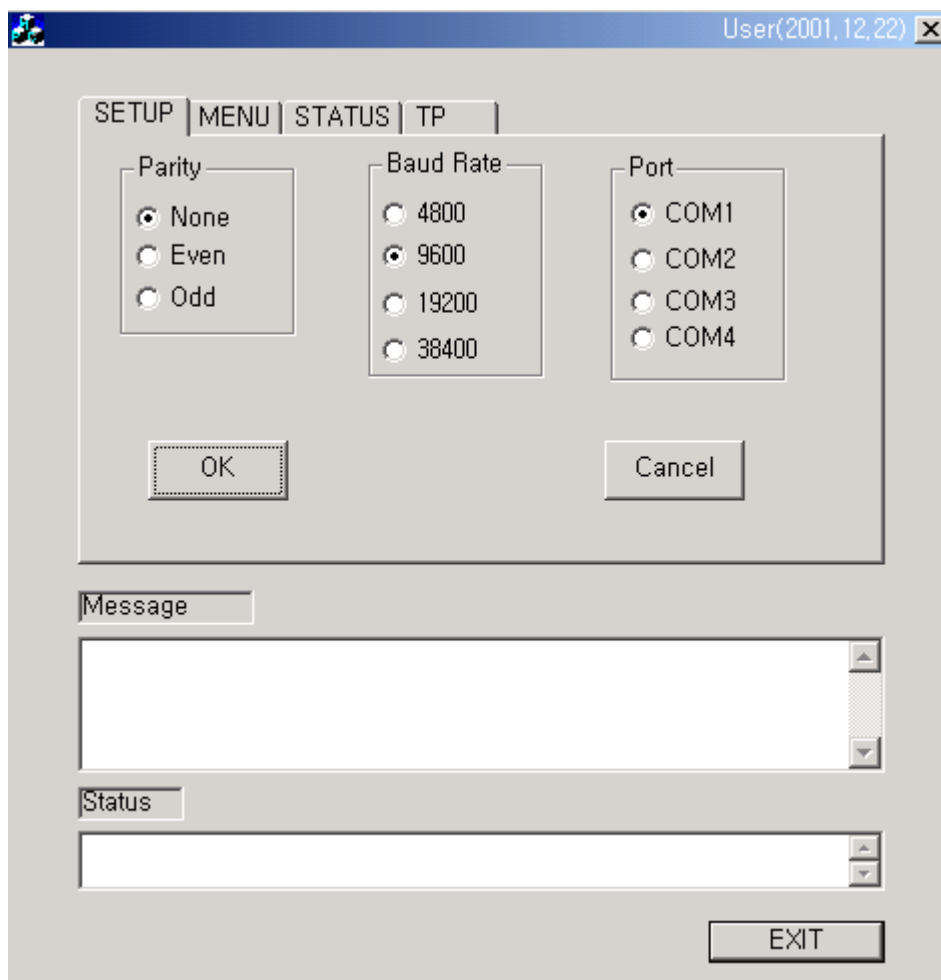

< Fig 1 : SETUP PAGE >



II. Page 2

- 1) Choose MENU page

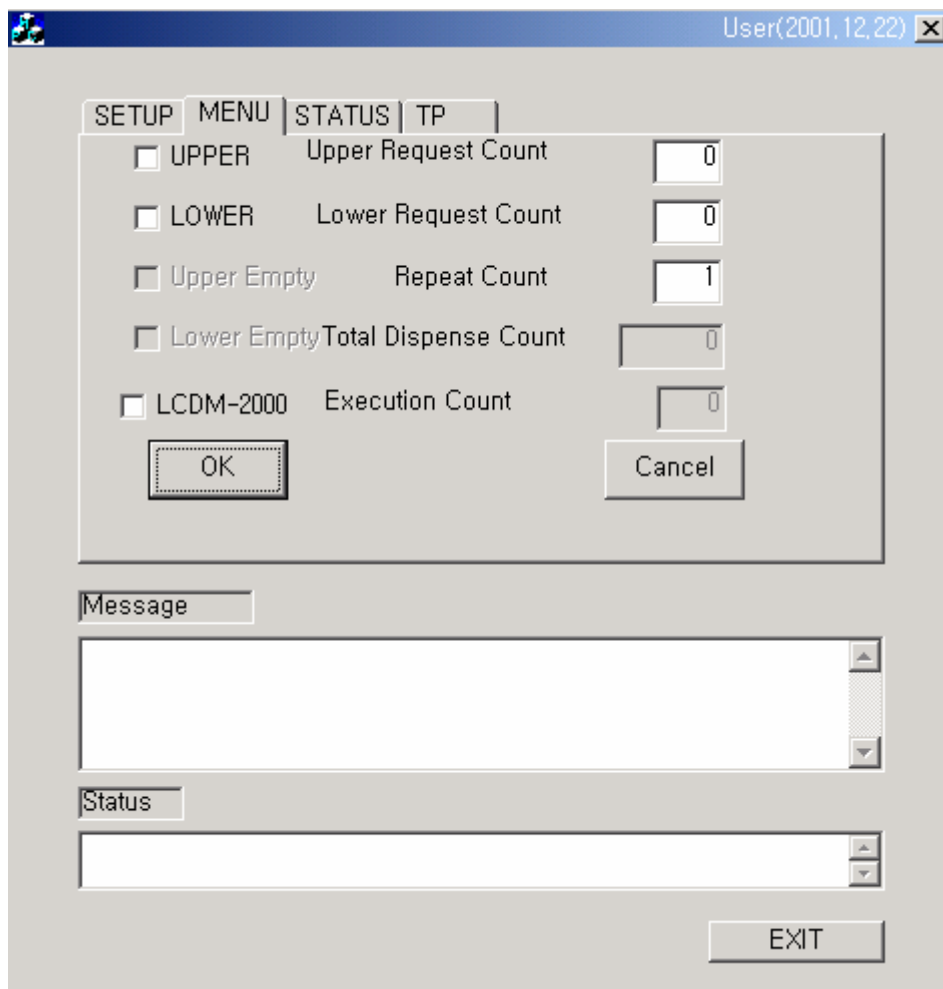

< Fig 2 : MENU PAGE >

- 2) Check UPPER or LOWER.
  - UPPER : to dispense from the upper cassette.
  - LOWER : to dispense from the lower cassette
  - BOTH CHECKED  
: to dispense the upper and then lower cassette
  
- 3) Check “LCDM-2000” which means the unit is LCDM-2000.  
(For LCDM-1000, do not check the box. This is related to error message.)

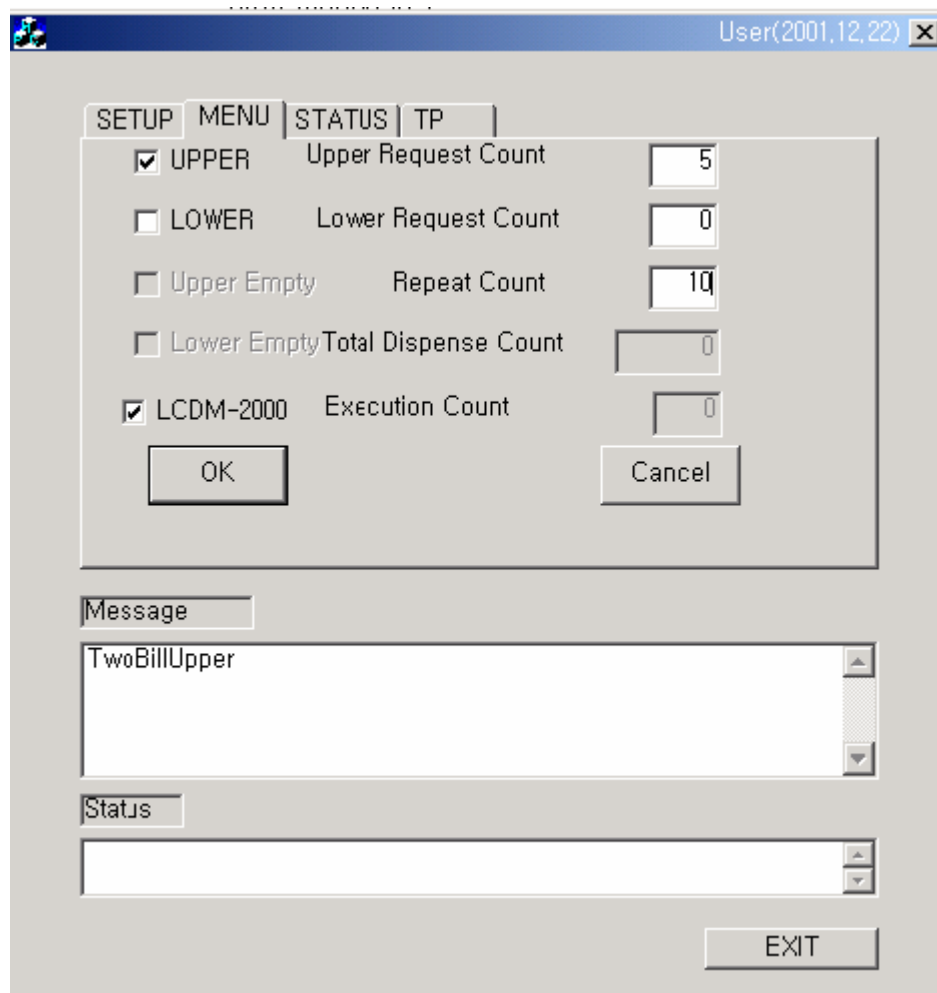

<Fig 3 : Five bills are dispensed 10 times from upper cassette>

- 4) Fill in the blanks of “Upper Request Count” , “Lower Request Count” and “Repeat Count”. (Recommended Values are from 1 ~20 for the XXX Request Count, and 1~999 for the Repeat Count.)

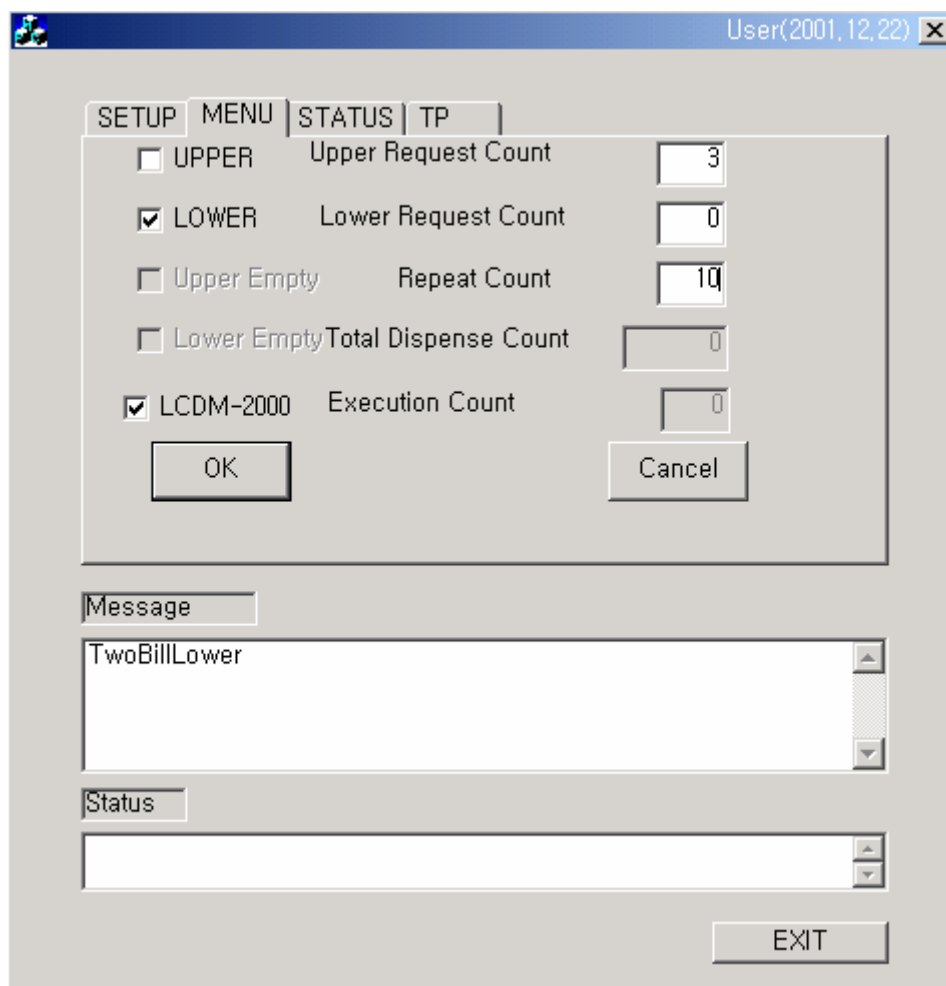

<Fig 4 : Three bills are dispensed 10 times from lower cassette>

- 5) In the case of both “UPPER” and “LOWER” checked like below, at first, one bill will be dispensed and then 4 bills will be dispensed sequentially.
- 6) Press “OK” button.
- 7) If Near-End occurs, “Upper Empty” or “Lower Empty” is checked with the V mark.

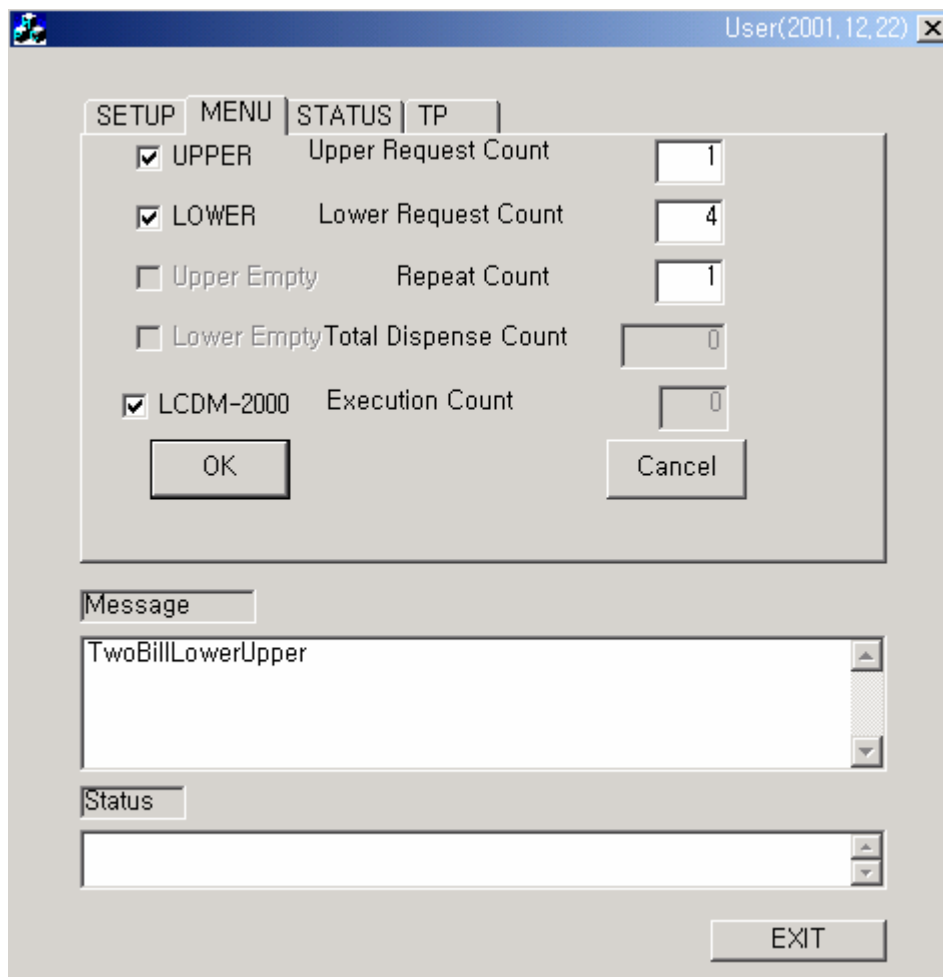

<Fig 4 : One bill is dispensed from Upper Cassette  
and Four bills are dispensed from Lower Cassette >

## III. Page 3

- 1) Choose STATUS page
- 2) Press “STATUS” button and all sensors are rechecked.  
This shows system status for you.
- 3) If you want to reset, press the button of “RESET”

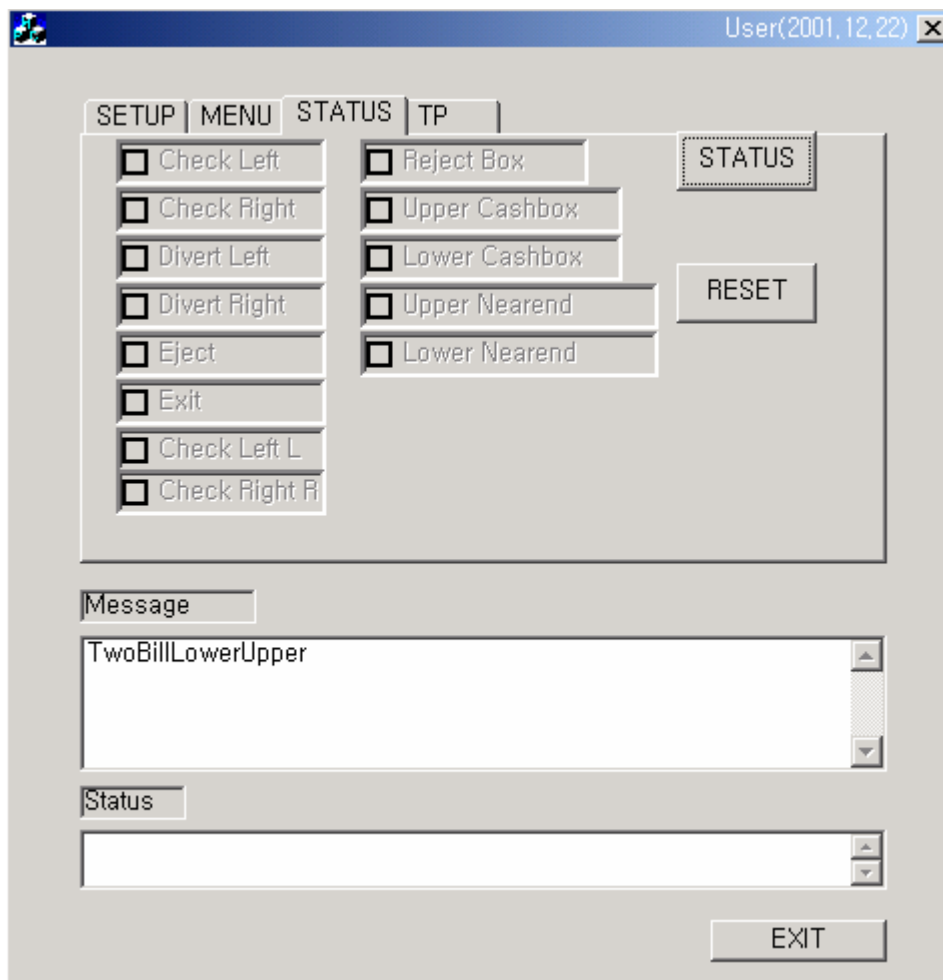

&lt; Fig 5 : STATUS PAGE &gt;

## IV. Page 4

- 1) Choose TP page
- 2) This page is about test program in our lab for checking each function and element of the unit.
- 3) Motor Speed, Bill Length, Diverting, RVDT Value and Clutch Tests can be performed and examined.

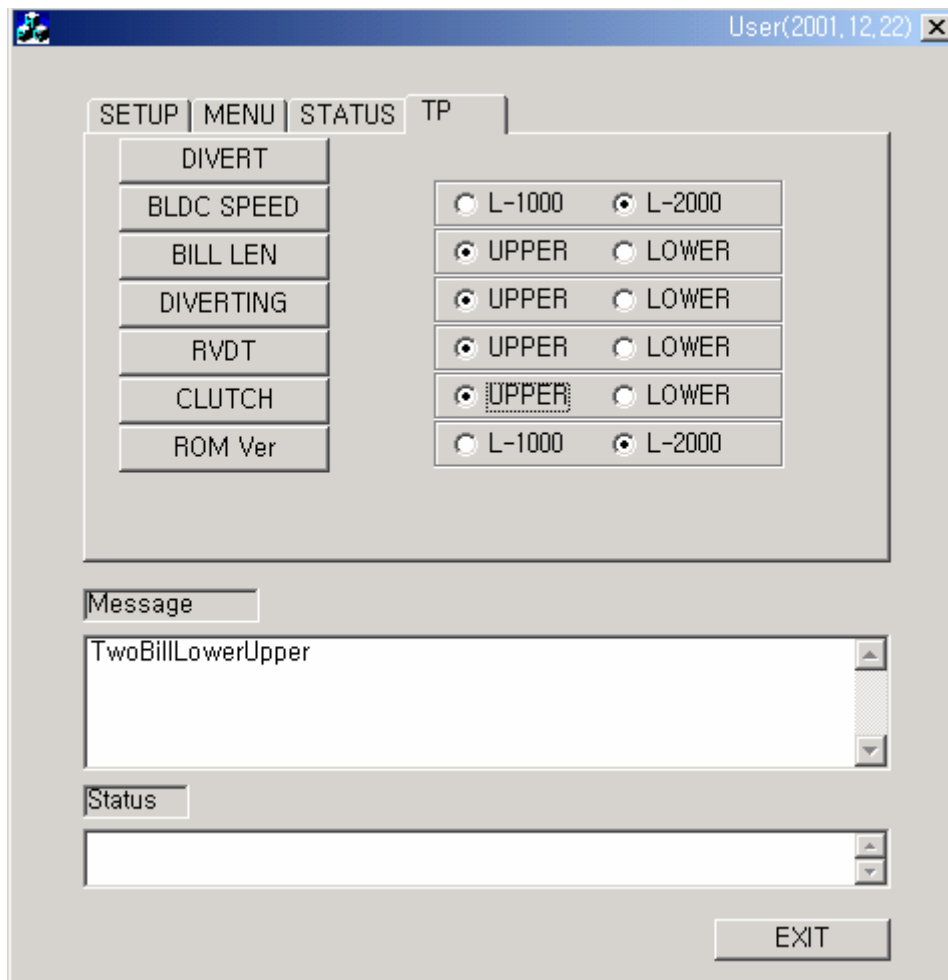

&lt; Fig 6 : TP PAGE &gt;